

COLONIAL SANDSTONE PRODUCTS PTY LTD

incorporating Formstone

ABN 52 065 746 090

25 PARAMOUNT DRIVE WANGARA WA 6065

TEL: 9302 1972 FAX: 9302 2161

WEB: www.colonialsandstone.com.au

Pavers

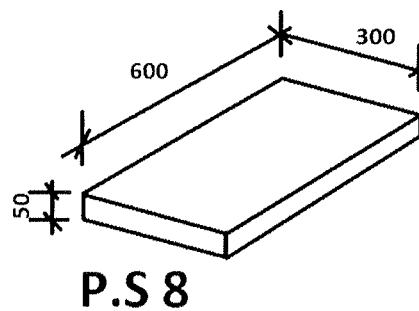
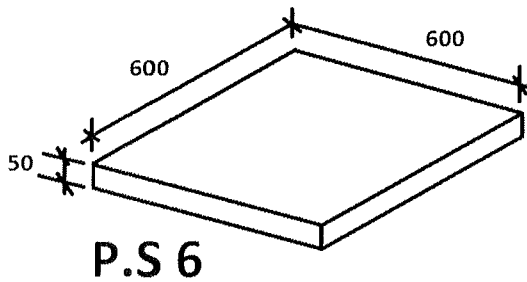
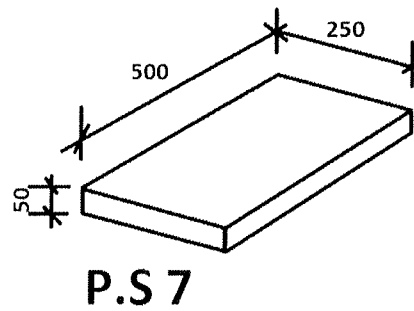
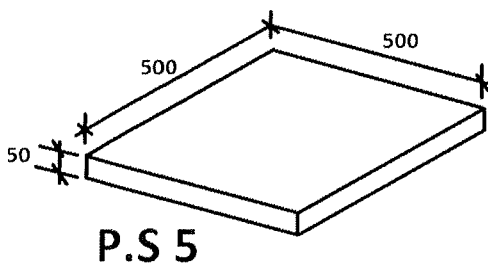
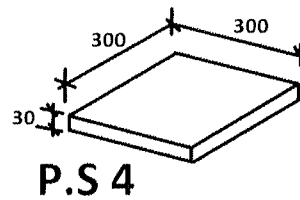
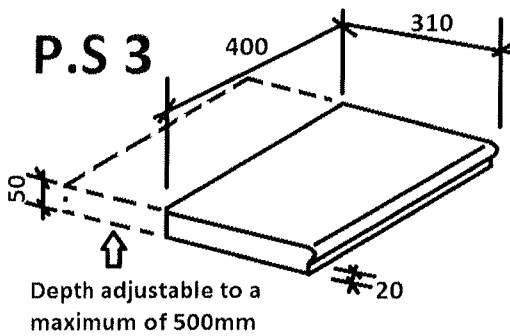
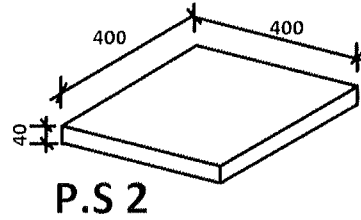
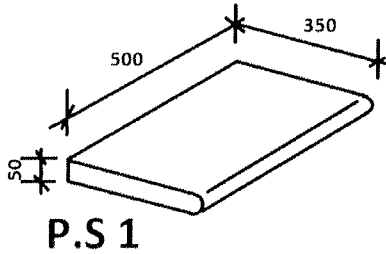

Please enquire with our staff for other designs and sizes

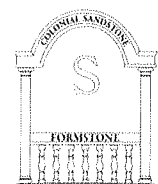

COLONIAL SANDSTONE PRODUCTS PTY LTD

incorporating Formstone

ABN 52 065 746 090

25 PARAMOUNT DRIVE WANGARA WA 6065

TEL: 9302 1972 FAX: 9302 2161

WEB: www.colonialsandstone.com.au

Pavers

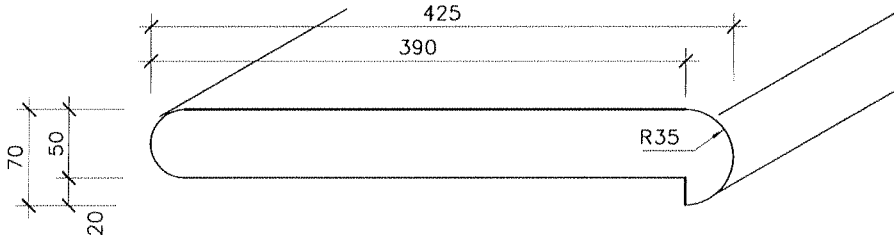

E.P 01

STANDARD LENGTH:
500MM

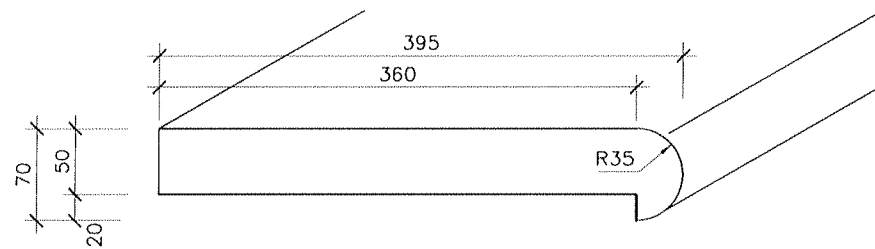

E.P 02

STANDARD LENGTH:
500MM

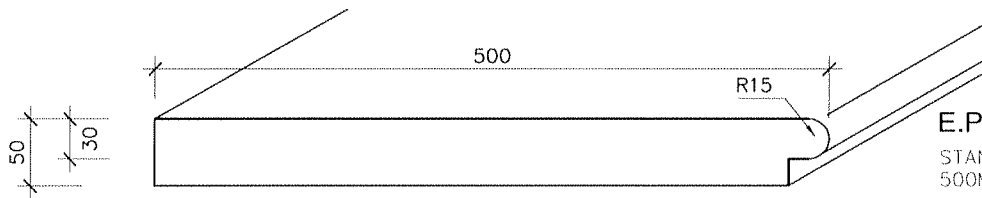

E.P 03

STANDARD LENGTH:
500MM

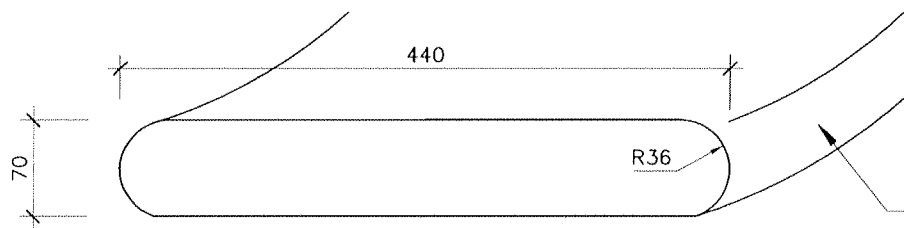

E.P 04

MAXIMUM LENGTH:
775MM

EXTERNAL CURVE
RADIUS: 1240MM

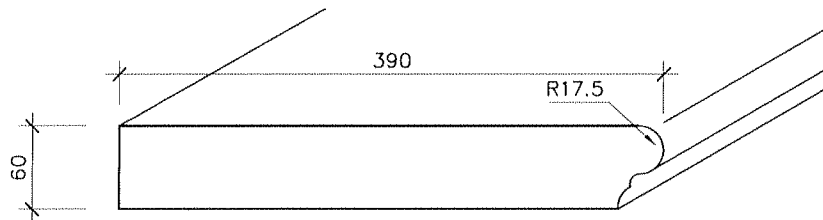

E.P 05

STANDARD LENGTH:
650MM

Please enquire with our staff for other designs and sizes



COLONIAL SANDSTONE PRODUCTS PTY LTD

incorporating Formstone

ABN 52 065 746 090

25 PARAMOUNT DRIVE WANGARA WA 6065

TEL: 9302 1972 FAX: 9302 2161

WEB: www.colonialsandstone.com.au

Pavers

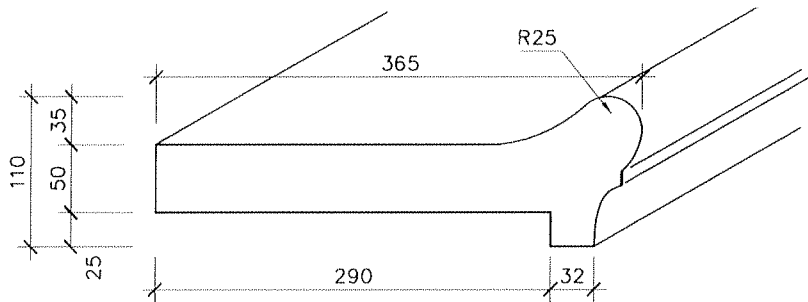

E.P 06

STANDARD LENGTH:
500MM

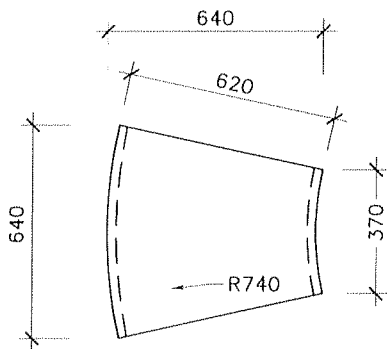

PLAN

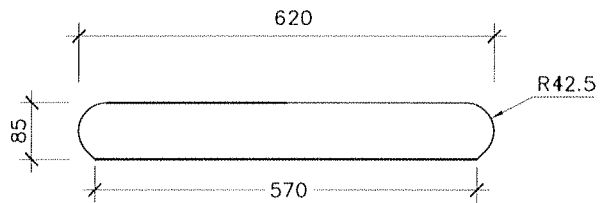

SIDE VIEW

EP 07 (SPA EDGE PAVER)

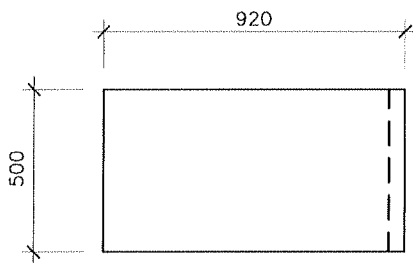

PLAN



SIDE VIEW

EP 08 (VERANDAH EDGE PAVER)

Please enquire with our staff for other designs and sizes

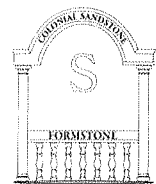

COLONIAL SANDSTONE PRODUCTS PTY LTD

incorporating Formstone

ABN 52 065 746 090

25 PARAMOUNT DRIVE WANGARA WA 6065

TEL: 9302 1972 FAX: 9302 2161

WEB: www.colonialsandstone.com.au

Pavers

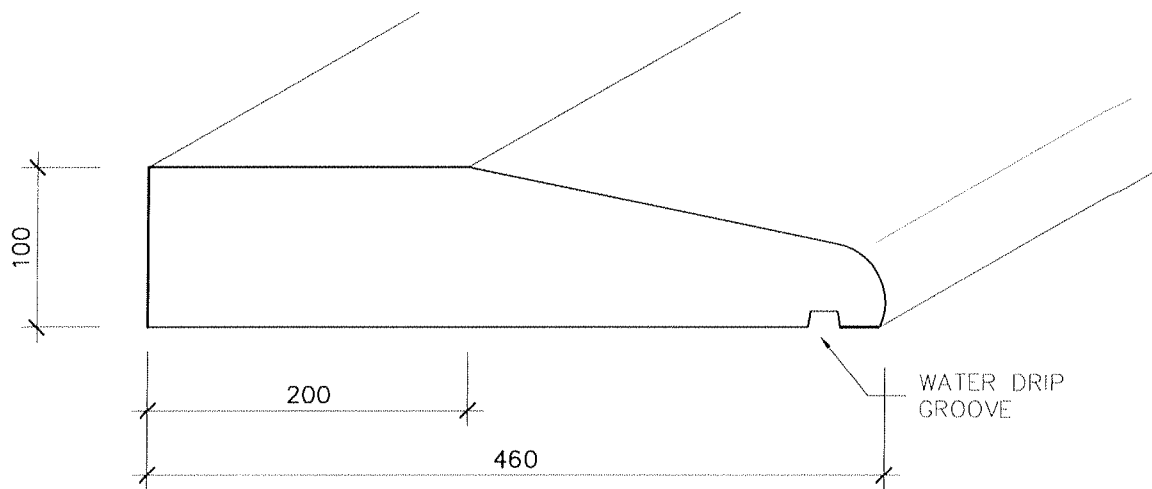

E.P 10 (WATERFALL EDGE PAVER)

AVAILABLE LENGTH: 1000MM

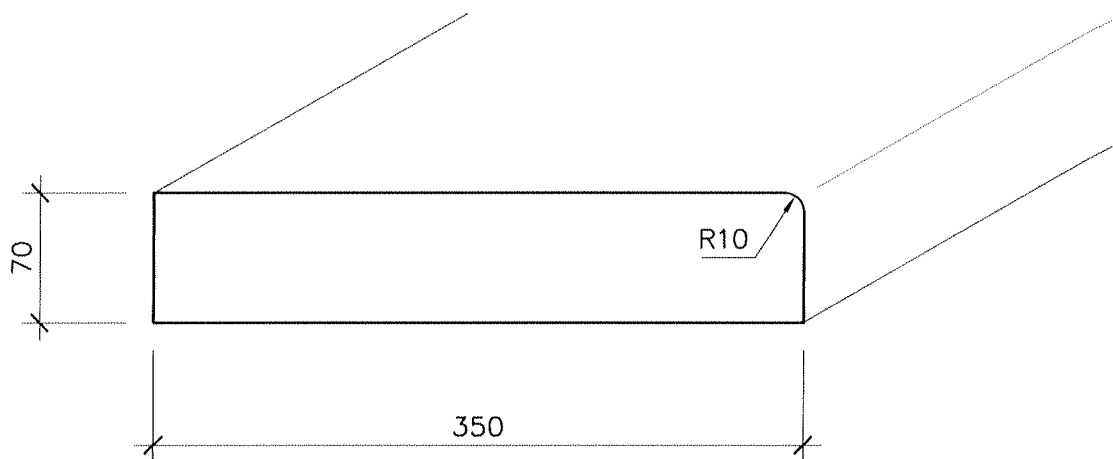

E.P 11 (SQUARE EDGE PAVER)

AVAILABLE LENGTH: 500MM

Please enquire with our staff for other designs and sizes



COLONIAL SANDSTONE PRODUCTS PTY LTD

incorporating Formstone

ABN 52 065 746 090

25 PARAMOUNT DRIVE WANGARA WA 6065

TEL: 9302 1972 FAX: 9302 2161

WEB: www.colonialsandstone.com.au

Pavers

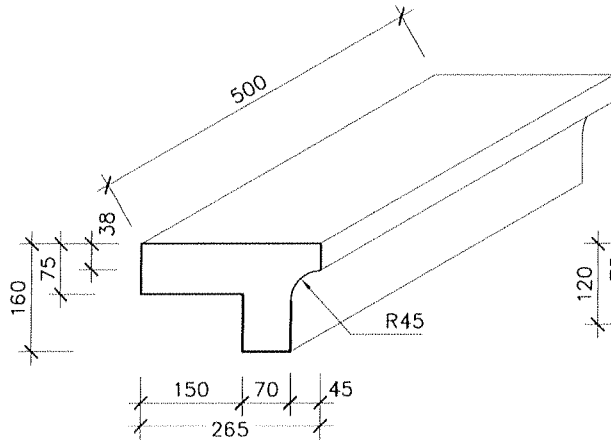

P.M 01

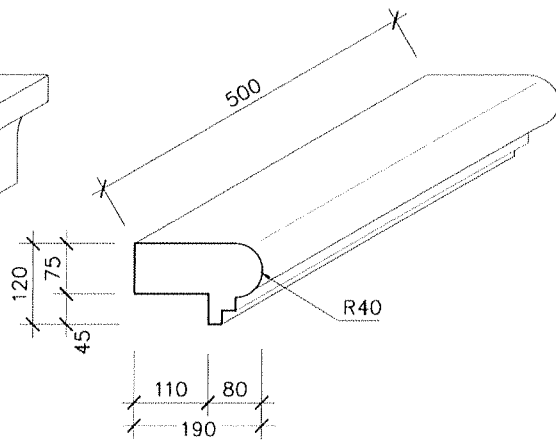

P.M 02

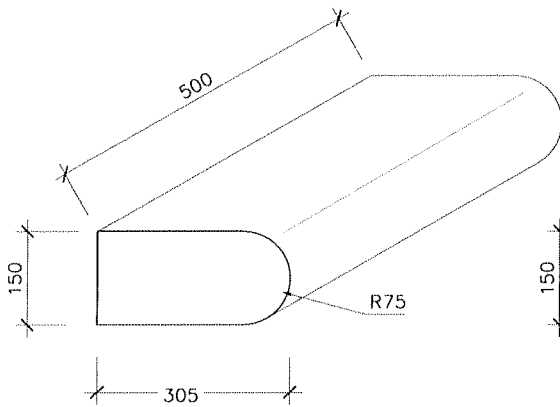

P.M 03

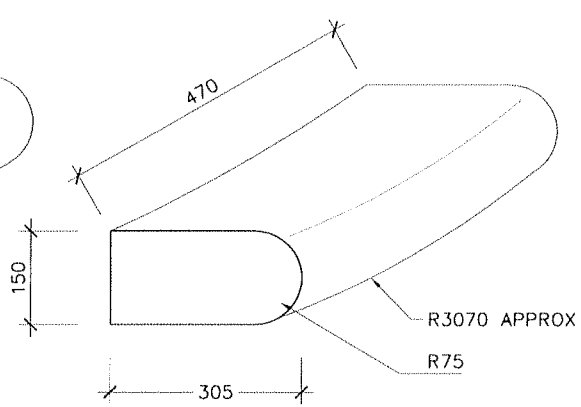

P.M 04

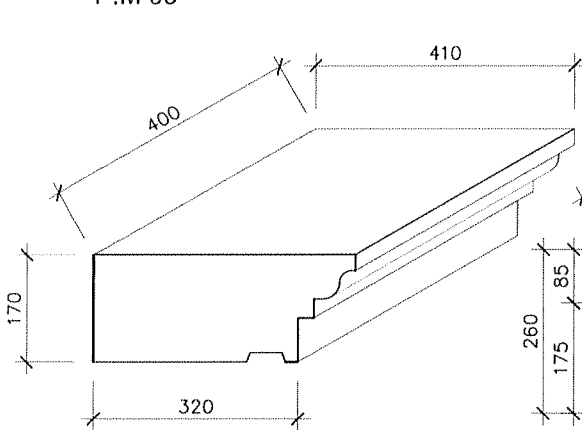

P.M 05

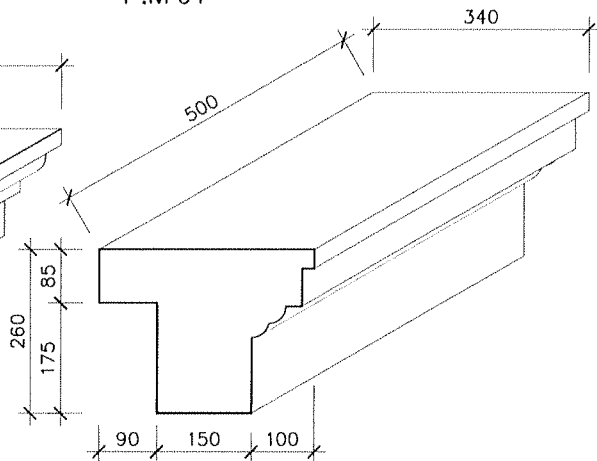

P.M 06

Please enquire with our staff for other designs and sizes

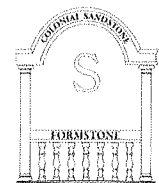

COLONIAL SANDSTONE PRODUCTS PTY LTD

incorporating Formstone

ABN 52 065 746 090

25 PARAMOUNT DRIVE WANGARA WA 6065

TEL: 9302 1972 FAX: 9302 2161

WEB: www.colonialsandstone.com.au

Pavers

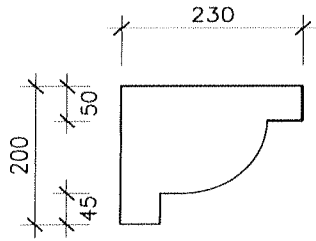

SIDE VIEW

P.M 07

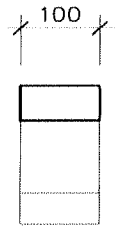

FRONT VIEW

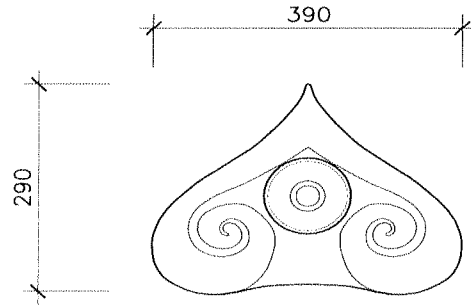

FRONT VIEW

P.M 08

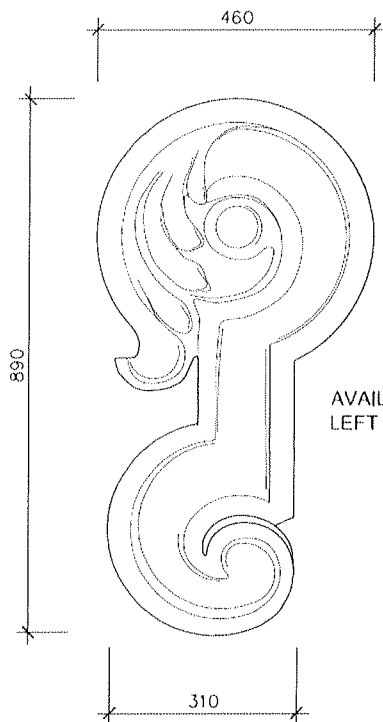

AVAILABLE
LEFT & RIGHT

FRONT VIEW

P.M 09
GABLE END

Please enquire with our staff for other designs and sizes

